

VICINITY MAP/NO SCALE

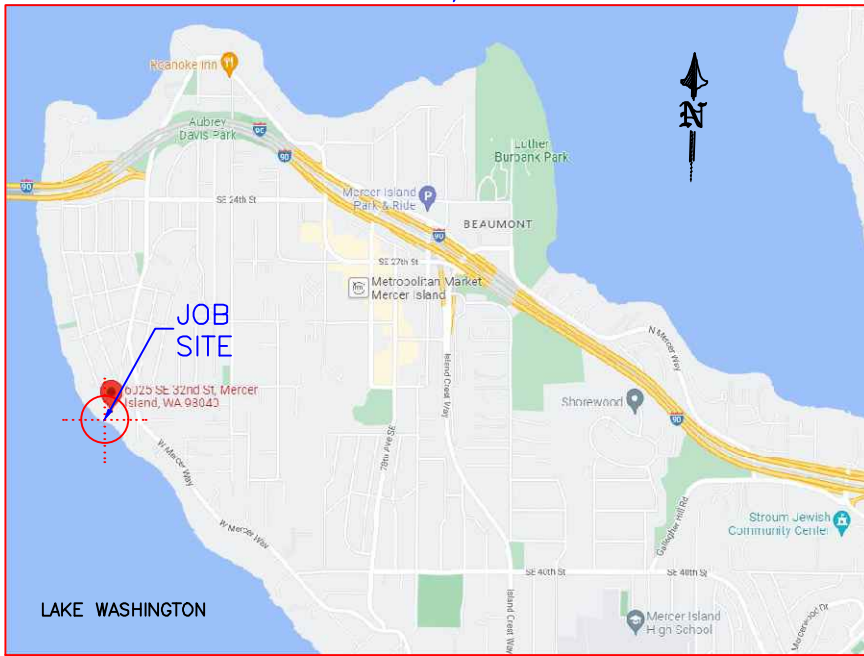

REVISED
03/29/2023

TO INCLUDE
PLANTING PLAN
ON SHEET 10.

LEGAL DESCRIPTION

SECTION: SE-11-24-04
TAXLOT #: 370890-0042 & 370890-0040
LAT: 47.580720 (47° 34' 50.592" N)
LONG: -122.250040 (122° 15' 0.144" W)

6025 SE 32ND ST. (370890-0042):
JERSEY WATER FRONT TO E SEATTLE LOT A MERCER ISLAND SHORT PLAT NO 93-1751 REC NO 9502069001 & ALTERATION TO SHORT PLAT REC NO 20070718900003 SD SHORT PLAT DAF - POR OF TRACTS 3 & 4 OF JERSEY WATER FRONT ADDITION TO EAST SEATTLE BEG AT MNMT #1 WCH IS AN IRON PIPE EMBEDDED IN CONCRETE AT APPROX THE NW COR OF TRACT 8 OF SD ADD & RNG TH S 10-49-00 E 116.70 FT TO MNMT #2 WCH IS AN IRON PIPE EMBEDDED IN CONCRETE WCH IS THE TPOB TH S 40-20-00 W 206.90 FT TO MNMT #3 WCH IS AN IRON PIPE EMBEDDED IN CONCRETE TH S 44-03-00 W 257.66 FT TO MNMT #4 WCH IS AN IRON PIPE EMBEDDED IN CONCRETE & ON THE SHORE OF LAKE WASHINGTON TH S 72-01-00 E 100.00 FT TO MNMT #5 WCH IS AN IRON PIPE TH N 47-17-40 E 316.17 FT TH N 05-10-00 W 160.00 FT TO MNMT #2 HINFTF DESIGNATED AS TPOB - TGW 2ND CL SH LDS ADJ LY BTWN NW LN & SELY LN OF ABOVE DESC TRACT EXTENDED SWLY

6027 SE 32ND ST. (370890-0040):
JERSEY WATER FRONT TO E SEATTLE LOT B MERCER ISLAND SHORT PLAT NO 93-1751 REC NO 9502069001 & ALTERATION TO SHORT PLAT REC NO 20070718900003 SD SHORT PLAT DAF - POR OF TRACTS 3 & 4 OF JERSEY WATER FRONT ADDITION TO EAST SEATTLE BEG AT MNMT #1 WCH IS AN IRON PIPE EMBEDDED IN CONCRETE AT APPROX THE NW COR OF TRACT 8 OF SD ADD & RNG TH S 10-49-00 E 116.70 FT TO MNMT #2 WCH IS AN IRON PIPE EMBEDDED IN CONCRETE WCH IS THE TPOB TH S 40-20-00 W 206.90 FT TO MNMT #3 WCH IS AN IRON PIPE EMBEDDED IN CONCRETE TH S 44-03-00 W 257.66 FT TO MNMT #4 WCH IS AN IRON PIPE EMBEDDED IN CONCRETE & ON THE SHORE OF LAKE WASHINGTON TH S 72-01-00 E 100.00 FT TO MNMT #5 WCH IS AN IRON PIPE TH N 47-17-40 E 316.17 FT TH N 05-10-00 W 160.00 FT TO MNMT #2 HINFTF DESIGNATED AS TPOB - TGW 2ND CL SH LDS ADJ LY BTWN NW LN & SELY LN OF ABOVE DESC TRACT EXTENDED SWLY

PROJECT DESIGNED BY:

Waterfront Construction Inc.

THIS DOCUMENT IS PROPRIETARY PROPERTY OF WATERFRONT CONSTRUCTION INC., AND IS NOT TO BE USED, IN WHOLE OR IN PART, FOR ANY OTHER PROJECT WITHOUT THE WRITTEN AUTHORIZATION OF WATERFRONT CONSTRUCTION INC.

AREA MAP/NO SCALE

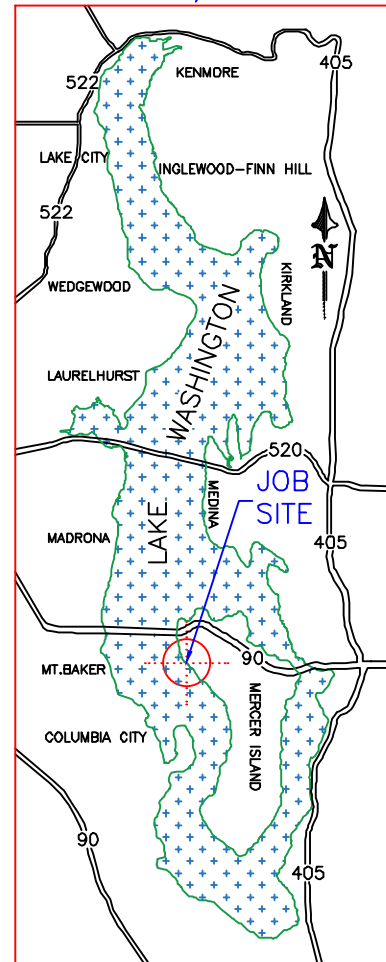

ADJACENT OWNERS:

- ① PROCTOR LANE TRUST
6005 SE 32ND ST.
MERCER ISLAND, WA 98040
- ② STUART JOHNSTON
6033 SE 32ND ST.
MERCER ISLAND, WA 98040

PROPOSED: NEW JOINT-USE DOCK

PURPOSE: PROVIDE ECOLOGICALLY SUSTAINABLE JOINT-USE MOORAGE & WATERWAY ACCESS

DATUM: C.O.E. MLLW=0.0'

DWG#: 22-32020-A3-1

APPLICANT: 6027 LLC c/o MELANIE PRITT

SITE ADD. 6025 & 6027 SE 32ND ST.
MERCER ISLAND, WA 98040

MAIL ADD. PO BOX 346
MERCER ISLAND, WA 98040

APPLICATION#:

PAGE: 1 OF: 10

DATE: 08/29/2022

SE 32ND ST.

REVISED
03/29/2023

TO INCLUDE
PLANTING PLAN
ON SHEET 10.



370890-0005

370890-0090

PROCTOR LANE TRUST
6005 SE 32ND ST.
MERCER ISLAND, WA 98040
370890-0009

JOB SITE
MELANIE PRITT
6027 SE 32ND ST.
MERCER ISLAND, WA 98040
370890-0040

JOB SITE
6027 32ND ST LLC
6025 SE 32ND ST.
MERCER ISLAND, WA 98040
370890-0042

MELANIE PRITT
6031 SE 32ND ST.
MERCER ISLAND, WA 98040
370890-0045

2
STUART JOHNSTON
6033 SE 32ND ST.
MERCER ISLAND, WA 98040
370890-0055

370890-0057

370890-0061

NORTH ADJACENT DOCK
NO WORK PROPOSED

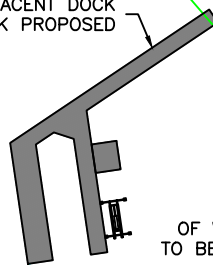

±35.3 SQFT
OF WOODEN DOCK
TO BE BE REMOVED
±20 LF OF CONCRETE BULKHEAD
TO BE BE REMOVED
±10 LF OF TIMBER BULKHEAD
TO BE BE REMOVED

LOCATION OF PROPOSED NEW JOINT USE DOCK

SUBTENDED LINE
TO ADJACENT STRUCTURES

SOUTH ADJACENT DOCKS
NO WORK PROPOSED

LAKE WASHINGTON

EXISTING SITE PLAN

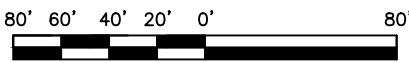

SCALE: 1"=80'

PROJECT DESIGNED BY:
Waterfront Construction Inc.
THIS DOCUMENT IS PROPRIETARY PROPERTY OF WATERFRONT
CONSTRUCTION INC., AND IS NOT TO BE USED, IN WHOLE OR IN
PART, FOR ANY OTHER PROJECT WITHOUT THE WRITTEN
AUTHORIZATION OF WATERFRONT CONSTRUCTION INC.

REFERENCE #:	
APPLICANT: 6027 LLC c/o MELANIE PRITT	
PROPOSED: NEW JOINT-USE DOCK	
SHEET: 2 OF: 10	NEAR/AT: LAKE WASHINGTON
DATE: 08/29/2022	DWG#: 22-32020-A3-2

SE 32ND ST.

REVISED
03/29/2023

TO INCLUDE
PLANTING PLAN
ON SHEET 10.



370890-0005

370890-0090

PROCTOR LANE TRUST
6005 SE 32ND ST.
MERCER ISLAND, WA 98040
370890-0009

JOB SITE

MELANIE PRITT
6027 SE 32ND ST.
MERCER ISLAND, WA 98040
370890-0040

TRAVERSE LINE PER 1921 SURVEY

GOV. MEANDER LINE

JOB SITE

6027 32ND ST LLC
6025 SE 32ND ST.
MERCER ISLAND, WA 98040
370890-0042

NORTH ADJACENT DOCK
NO WORK PROPOSED

MELANIE PRITT
6031 SE 32ND ST.
MERCER ISLAND, WA 98040
370890-0045

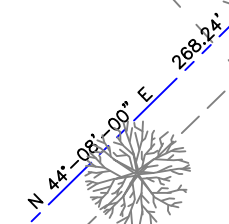
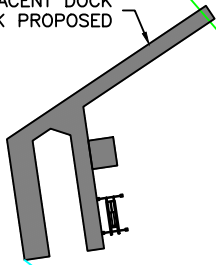

STUART JOHNSTON
6033 SE 32ND ST.
MERCER ISLAND, WA 98040
370890-0055

PROPOSED NEW 650.75 SQFT DOCK
& (2) NEW BOATLIFTS

SUBTENDED LINE
TO ADJACENT STRUCTURES

MEANDER LINE PER 1921 SURVEY

370890-0057

LAKE WASHINGTON

SOUTH ADJACENT DOCKS
NO WORK PROPOSED

370890-0061

PROJECT DESIGNED BY:

Waterfront Construction Inc.

THIS DOCUMENT IS PROPRIETARY PROPERTY OF WATERFRONT
CONSTRUCTION INC., AND IS NOT TO BE USED, IN WHOLE OR IN
PART, FOR ANY OTHER PROJECT WITHOUT THE WRITTEN
AUTHORIZATION OF WATERFRONT CONSTRUCTION INC.

PROPOSED SITE PLAN

80' 60' 40' 20' 0' 80'



SCALE: 1"=80'

REFERENCE #:

APPLICANT: 6027 LLC c/o MELANIE PRITT

PROPOSED: NEW JOINT-USE DOCK

SHEET: 3 OF 10

NEAR/AT: LAKE WASHINGTON

DATE: 08/29/2022

DWG#: 22-32020-A3-3

REVISED
03/29/2023

TO INCLUDE
PLANTING PLAN
ON SHEET 10.



±35.3 SQFT
OF WOODEN DOCK
TO BE BE REMOVED

PL

20'

19'

17'

16'

15'

14'

13'

12'

11'

10'

±20 LF OF CONCRETE BULKHEAD
TO BE BE REMOVED

±10 LF OF TIMBER BULKHEAD
TO BE BE REMOVED

LOCATION OF PROPOSED NEW JOINT USE DOCK

8" CONCRETE WALL TO REMAIN

50.07'

50.07'

OHWL PER DAVID EVANS &
ASSOCIATES INC. 12/06/2018

PL

21'

20'

19'

18'

17'

16'

15'

APPROX. LOCATION OF SEWER LINE PER
CITY OF MERCER ISLAND GIS

ELEVATION CONTOURS PER
DAVID EVANS & ASSOCIATES INC.
12/06/2018 (NAVD 1988)

14'

13'

SUBTENDED LINE
TO ADJACENT STRUCTURES

EXISTING SITE DETAIL

20' 15' 10' 5' 0' 20'



SCALE: 1"=20'

LAKE WASHINGTON

PROJECT DESIGNED BY:

Waterfront Construction Inc.

THIS DOCUMENT IS PROPRIETARY PROPERTY OF WATERFRONT
CONSTRUCTION INC., AND IS NOT TO BE USED, IN WHOLE OR IN
PART, FOR ANY OTHER PROJECT WITHOUT THE WRITTEN
AUTHORIZATION OF WATERFRONT CONSTRUCTION INC.

REFERENCE #:	
APPLICANT: 6027 LLC c/o MELANIE PRITT	
PROPOSED: NEW JOINT-USE DOCK	
SHEET: 4 OF: 10	NEAR/AT: LAKE WASHINGTON
DATE: 08/29/2022	DWG#: 22-32020-A3-4

REVISED
03/29/2023

TO INCLUDE
PLANTING PLAN
ON SHEET 10.

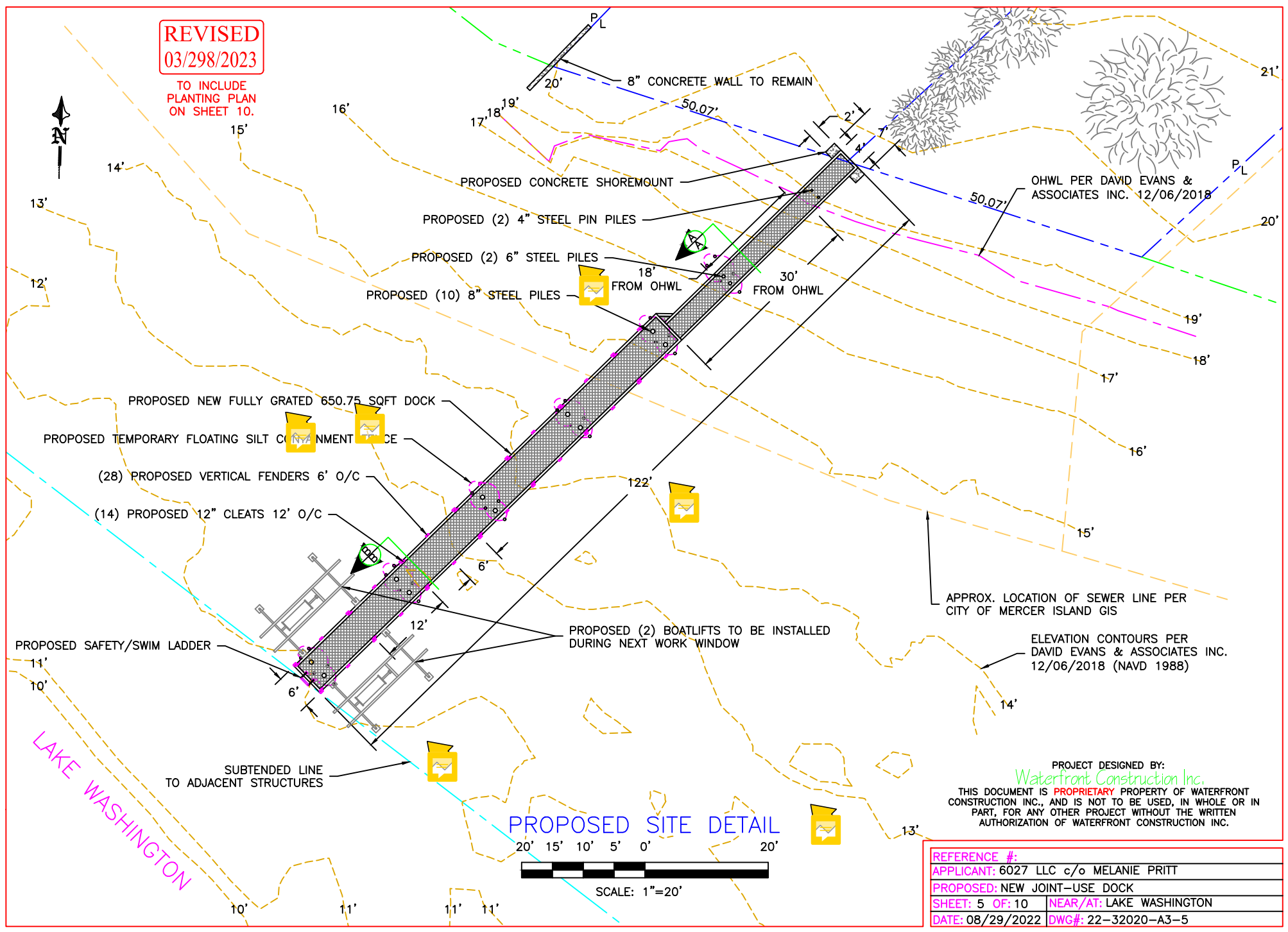

PROPOSED SITE DETAIL

PROJECT DESIGNED BY:
Waterfront Construction Inc.
THIS DOCUMENT IS PROPRIETARY PROPERTY OF WATERFRONT CONSTRUCTION INC., AND IS NOT TO BE USED, IN WHOLE OR IN PART, FOR ANY OTHER PROJECT WITHOUT THE WRITTEN AUTHORIZATION OF WATERFRONT CONSTRUCTION INC.

REFERENCE #:	
APPLICANT: 6027 LLC c/o MELANIE PRITT	
PROPOSED: NEW JOINT-USE DOCK	
SHEET: 5 OF 10	NEAR/AT: LAKE WASHINGTON
DATE: 08/29/2022	DWG#: 22-32020-A3-5

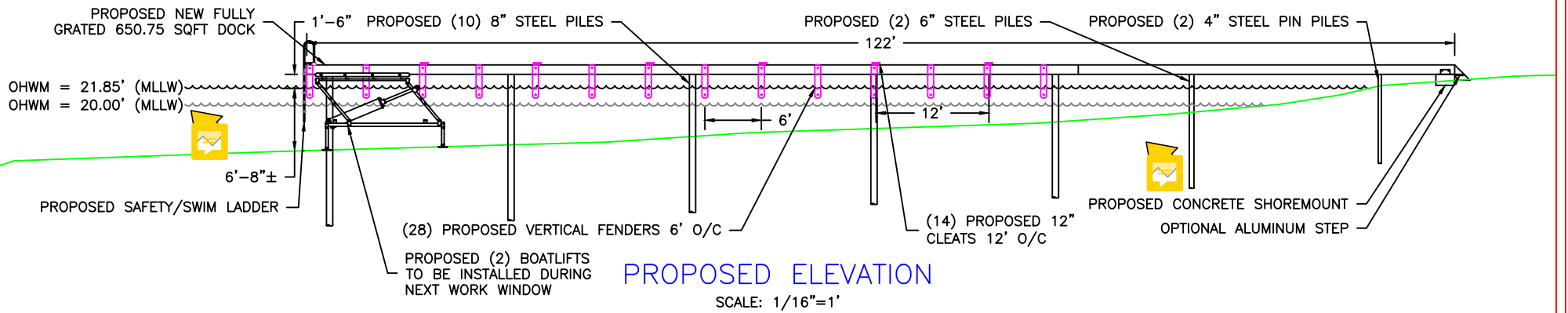

PROPOSED FRAMING PLAN

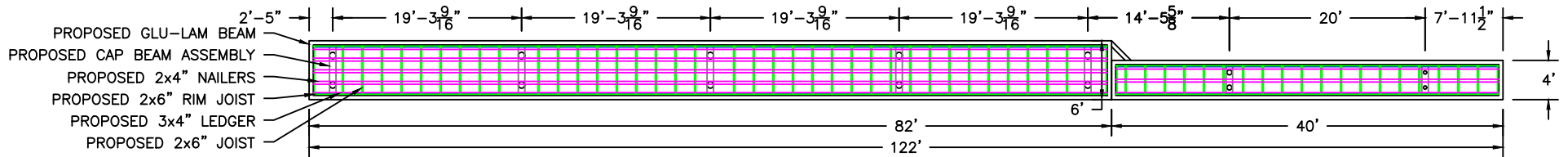

SCALE: 1/16"=1'

MATERIAL LIST

PART	SPECS	TREATMENT
PILING	X-STRONG 4", 6" & 8"	EPOXY
CAPS	W6x15 "I" BEAM	GALVANIZED
GLU-LAMS	5 1/8"x12" DF	ACZA
JOIST	2"x6" DF #2 OR BTR	ACZA
RIM JOIST	2"x6" DF #2 OR BTR	ACZA
NAILERS	3"x4" DF #2 OR BTR	ACZA
LEDGERS	3"x4" DF #2 OR BTR	ACZA
GRATING	MOLDED PLASTIC	NONE
HARDWARE	STEEL	STAINLESS OR HDG.

REVISED
03/29/2023

TO INCLUDE
PLANTING PLAN
ON SHEET 10.

REFERENCE #:	
APPLICANT:	6027 LLC c/o MELANIE PRITT
PROPOSED:	NEW JOINT-USE DOCK
SHEET: 6 OF: 10	NEAR/AT: LAKE WASHINGTON
DATE: 08/29/2022	DWG#: 22-32020-A3-6

PROJECT DESIGNED BY:

Waterfront Construction Inc.

THIS DOCUMENT IS PROPRIETARY PROPERTY OF WATERFRONT CONSTRUCTION INC., AND IS NOT TO BE USED, IN WHOLE OR IN PART, FOR ANY OTHER PROJECT WITHOUT THE WRITTEN AUTHORIZATION OF WATERFRONT CONSTRUCTION INC.

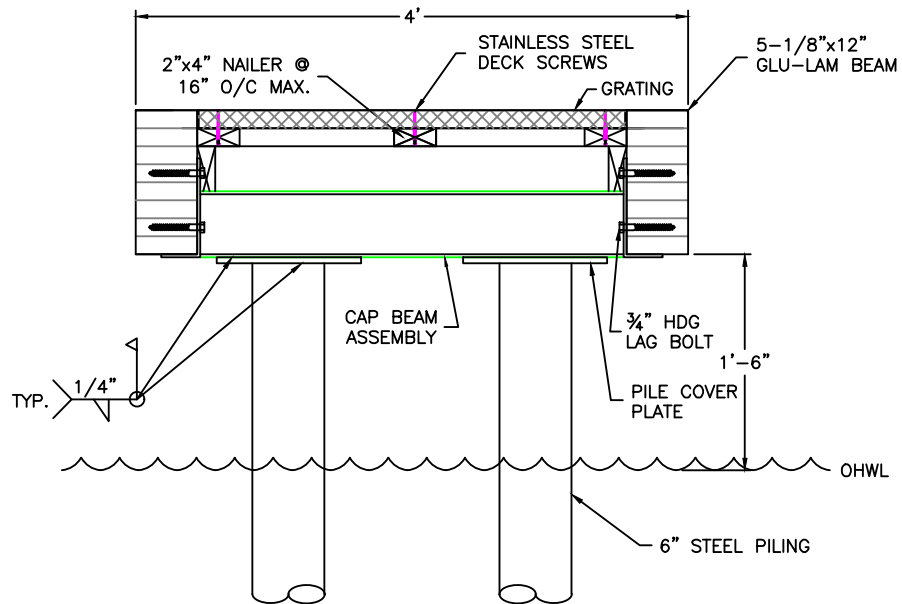

PROPOSED SECTION VIEW A-A

SCALE: 3/4"=1'

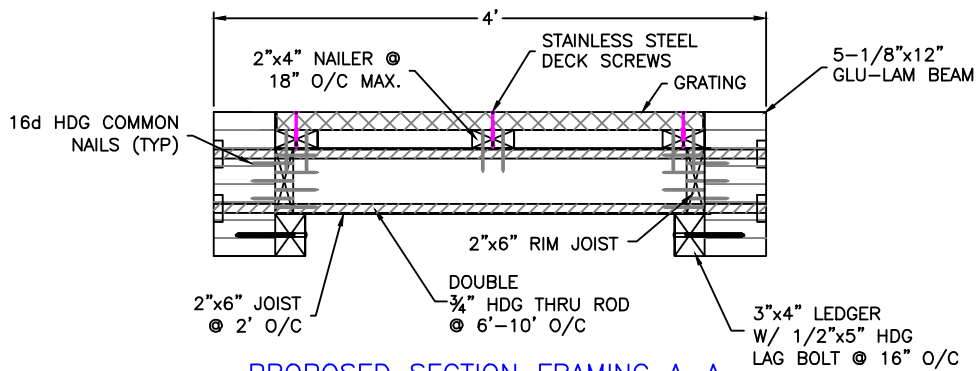

PROPOSED SECTION FRAMING A-A

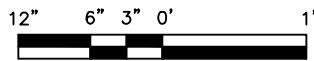

SCALE: 3/4"=1'

REVISED
03/29/2023

TO INCLUDE
PLANTING PLAN
ON SHEET 10.

PROJECT DESIGNED BY:

Waterfront Construction Inc.

THIS DOCUMENT IS PROPRIETARY PROPERTY OF WATERFRONT CONSTRUCTION INC., AND IS NOT TO BE USED, IN WHOLE OR IN PART, FOR ANY OTHER PROJECT WITHOUT THE WRITTEN AUTHORIZATION OF WATERFRONT CONSTRUCTION INC.

REFERENCE #:

APPLICANT: 6027 LLC c/o MELANIE PRITT

PROPOSED: NEW JOINT-USE DOCK

SHEET: 7 OF 10 NEAR/AT: LAKE WASHINGTON

DATE: 08/29/2022 DWG#: 22-32020-A3-7

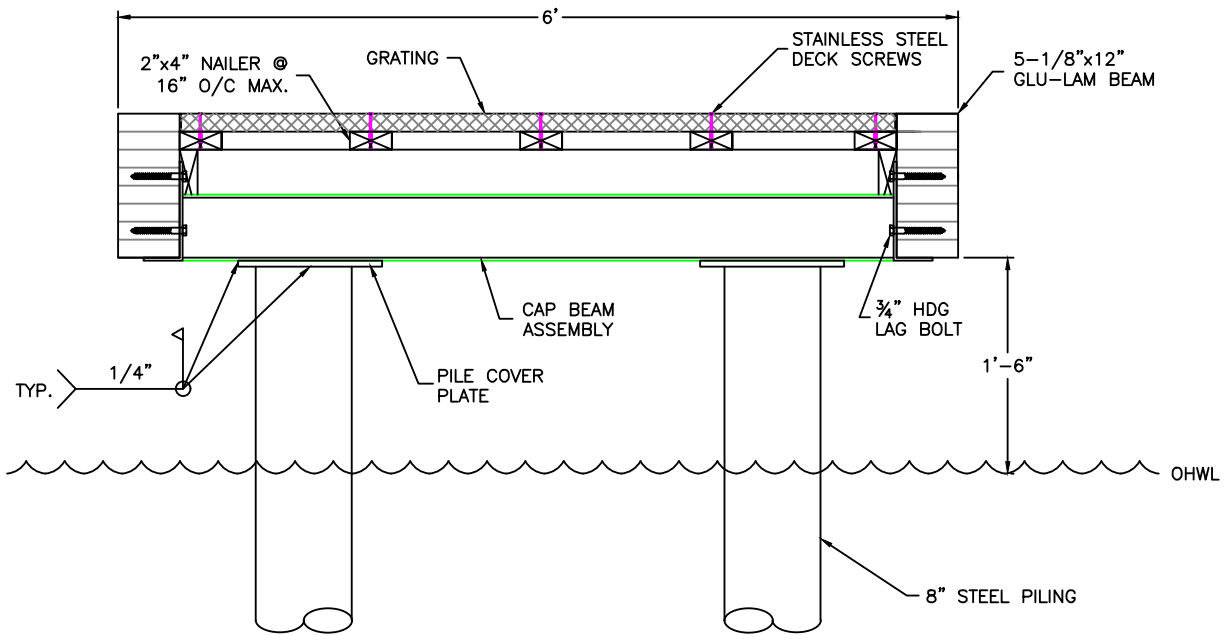

PROPOSED SECTION VIEW B-B
SCALE: 3/4"=1'

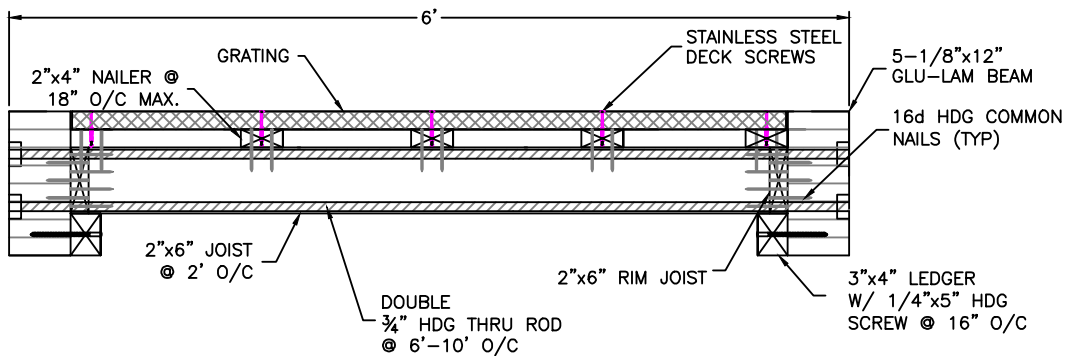

PROPOSED SECTION FRAMING B-B

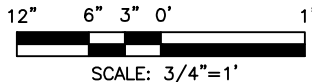

REVISED
03/29/2023

TO INCLUDE
PLANTING PLAN
ON SHEET 10.

PROJECT DESIGNED BY:

Waterfront Construction Inc.

THIS DOCUMENT IS PROPRIETARY PROPERTY OF WATERFRONT CONSTRUCTION INC., AND IS NOT TO BE USED, IN WHOLE OR IN PART, FOR ANY OTHER PROJECT WITHOUT THE WRITTEN AUTHORIZATION OF WATERFRONT CONSTRUCTION INC.

REFERENCE #:

APPLICANT: 6027 LLC c/o MELANIE PRITT

PROPOSED: NEW JOINT-USE DOCK

SHEET: 8 OF 10 NEAR/AT: LAKE WASHINGTON

DATE: 08/29/2022 DWG#: 22-32020-A3-8

PART #	NOMENCLATURE OR DESCRIPTION	MATERIAL SPECIFICATION
4	STIFFENER PLATES	5"x2-1/2"x1/4" STEEL PLATE
3	W6x15 "I" BEAM	6" 15 LB PER FOOT I-BEAM
2	BACK BEAM PLATE	18"x9"x5/12" STEEL PLATE
1	BOTTOM BEAM PLATE	18"x3"x5/12" STEEL PLATE

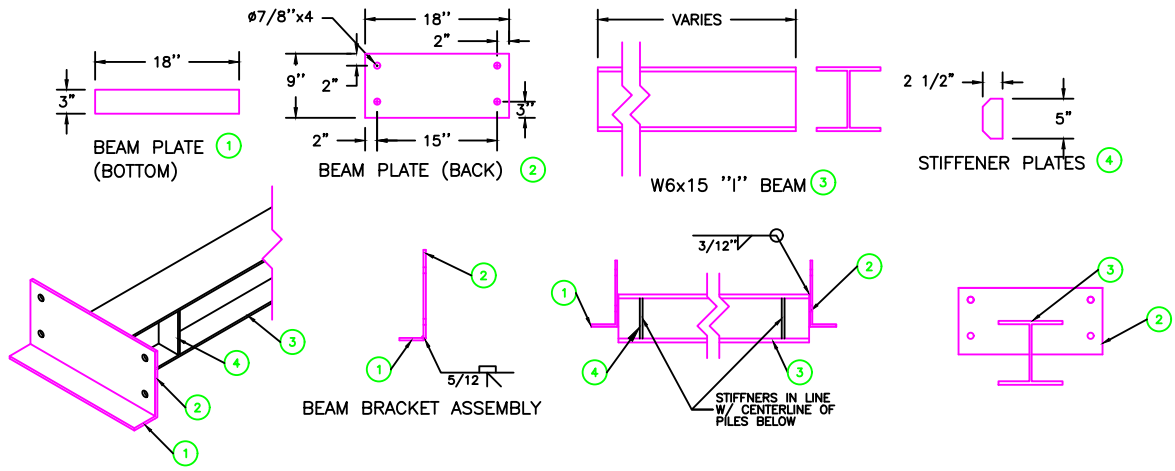

STEEL CAP ASSEMBLY

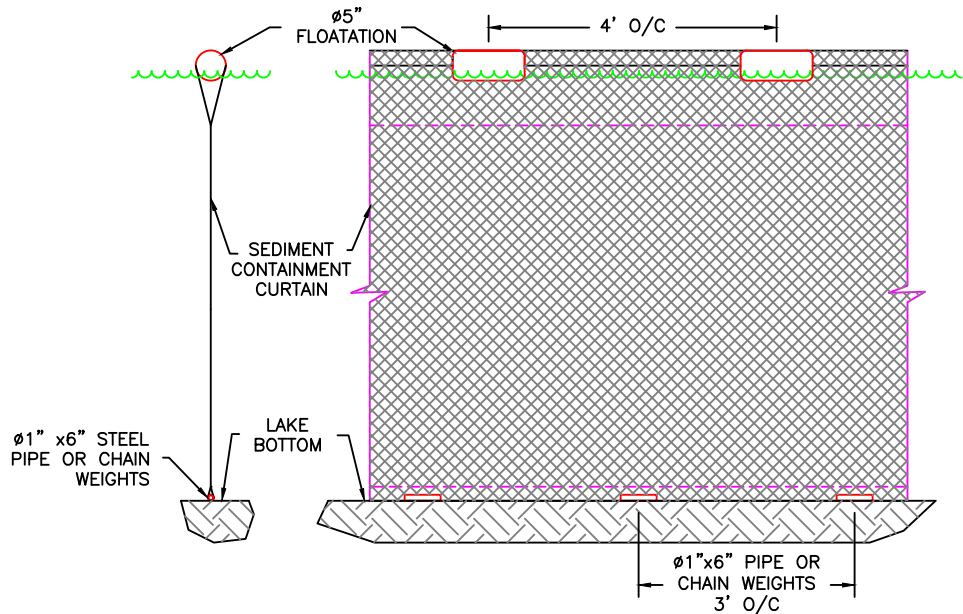
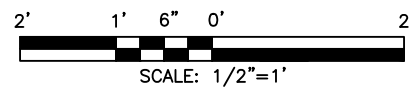

TEMP. FLOATING SILT CONTAINMENT FENCE

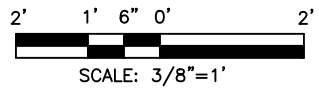

REVISED
03/29/2023

TO INCLUDE
PLANTING PLAN
ON SHEET 10.

PROJECT DESIGNED BY:
Waterfront Construction Inc.
THIS DOCUMENT IS PROPRIETARY PROPERTY OF WATERFRONT CONSTRUCTION INC., AND IS NOT TO BE USED, IN WHOLE OR IN PART, FOR ANY OTHER PROJECT WITHOUT THE WRITTEN AUTHORIZATION OF WATERFRONT CONSTRUCTION INC.

REFERENCE #:	
APPLICANT:	6027 LLC c/o MELANIE PRITT
PROPOSED:	NEW JOINT-USE DOCK
SHEET:	9 OF 10
NEAR/AT:	LAKE WASHINGTON
DATE:	08/29/2022
DWG#:	22-32020-A3-9

REVISED
03/29/2023

TO INCLUDE
PLANTING PLAN
ON SHEET 10.

PROCTOR LANE TRUST
6005 SE 32ND ST.
MERCER ISLAND, WA 98040
370890-0009

JOB SITE
MELANIE PRITT
6027 SE 32ND ST.
MERCER ISLAND, WA 98040
370890-0040

JOB SITE
6027 32ND ST LLC
6025 SE 32ND ST.
MERCER ISLAND, WA 98040
370890-0042

MELANIE PRITT
6031 SE 32ND ST.
MERCER ISLAND, WA 98040
370890-0045

STUART JOHNSTON
6033 SE 32ND ST.
MERCER ISLAND, WA 98040
370890-0055

370890-0057

370890-0067

NORTH ADJACENT
DOCK, NO WORK
PROPOSED

DOUGLAS FIR

WESTERN SERVICEBERRY

SNOWBERRY, TYPICAL

PROPOSED NEW 650.75 SQFT DOCK

SHORE PINE

SOUTH ADJACENT DOCKS
NO WORK PROPOSED

SUBTENDED LINE
TO ADJACENT STRUCTURES

LAKE WASHINGTON
PROPOSED PLANTING PLAN

80' 60' 40' 20' 0' 80'



SCALE: 1"=80'

PLANT SCHEDULE

Common Name	Scientific Name	Qty	Size
TREES			
Western Serviceberry	<i>Amelanchier alnifolia</i>	1	Min. 3' Height
Shore Pine	<i>Pinus contorta var. contorta</i>	1	Min. 4' Height
Douglas Fir	<i>Pseudotsuga menziesii</i>	1	Min. 4' Height
SHRUBS			
Snowberry	<i>Symphoricarpos albus</i>	2	Min. 12" Height
Total Plants:		5	

NOTES:

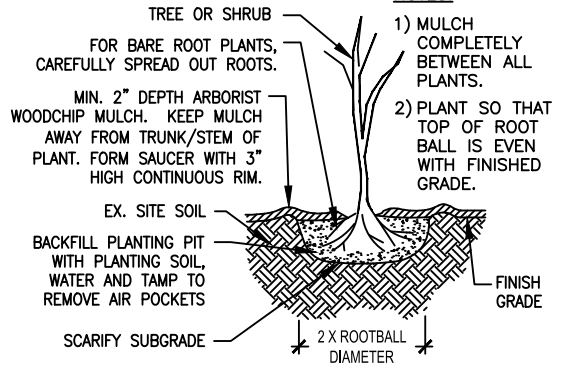

TYPICAL TREE OR SHRUB PLANTING

NOT TO SCALE

PROJECT DESIGNED BY:



3639 PALATINE AVE N
SEATTLE, WA 98103
206-634-9193

REFERENCE #:

APPLICANT: 6027 LLC c/o MELANIE PRITT
PROPOSED: NEW JOINT-USE DOCK
SHEET: 10 OF 10 NEAR/AT: LAKE WASHINGTON
DATE: 08/29/2022 DWG#: 22-32020-A3-10